

## 11. Exploded View

ERVD010 ERVD015 ERVD020 ERVD030 ERVD050 ERVD060

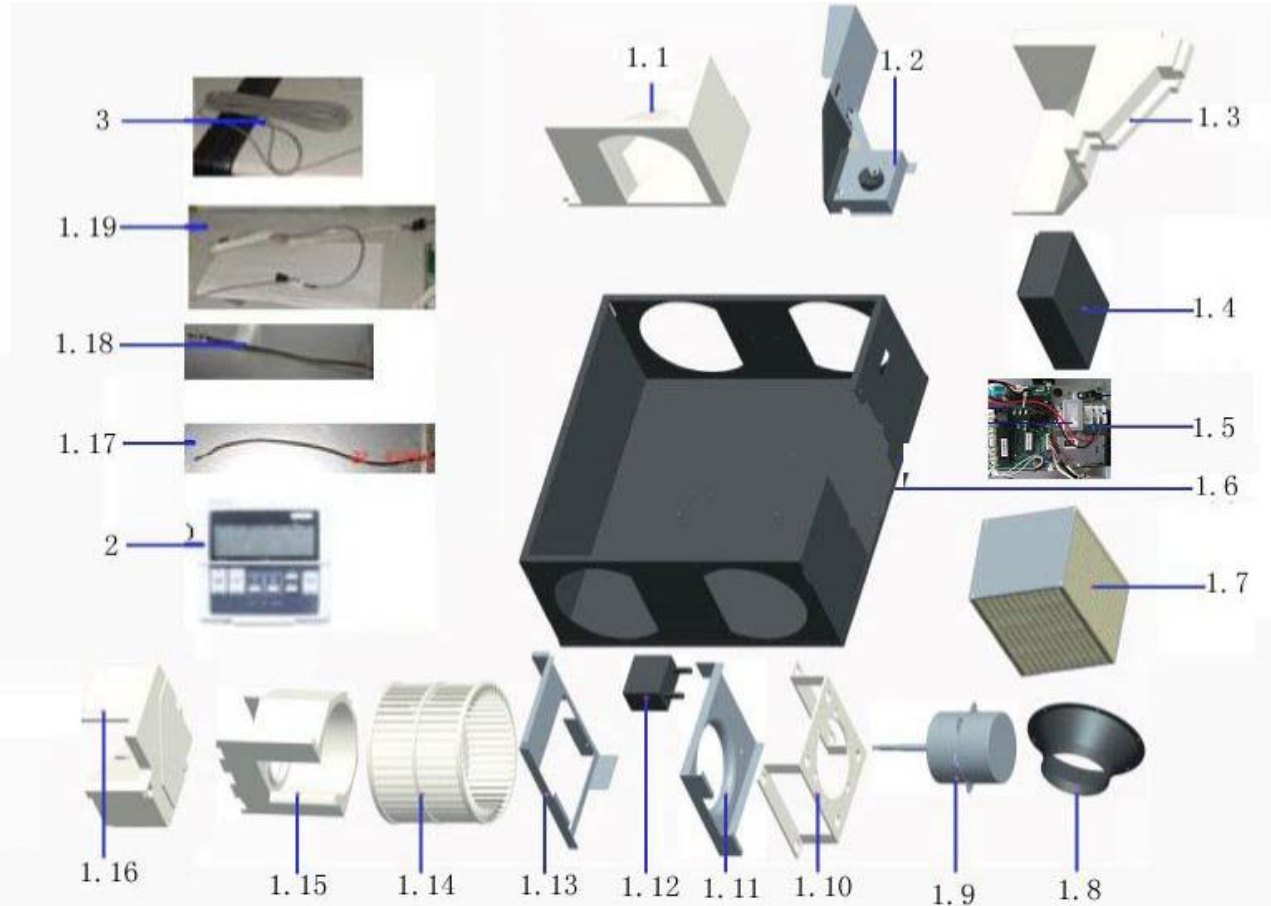

NO.	Part Name	Quantity
1.1	Inlet channel	2
1.2	Bypass part	1
1.3	Partition board	2
1.4	Electrical box	1
1.5	Electrical box ass'y (RoHS)	1
1.6	Chassis	1
1.7	Heat exchange core	1
1.8	Inlet/Outlet air	4
1.9	Fan Motor	2
1.10	Motor bracket	2
1.11	Guide plate	2
1.12	Motor capacitor	2
1.13	Fan bracket	2
1.14	Fan	2
1.15	Volute shell	2
1.16	Bypass channel	1
1.17	Room temp sensor ass'y (RoHS)	1
1.18	Temp. sensor (T1) (RoHS)	1
1.19	Display board ass'y (M54) (RoHS)	1
2	Wired Controller	1
3	Connecting wire assembly	1

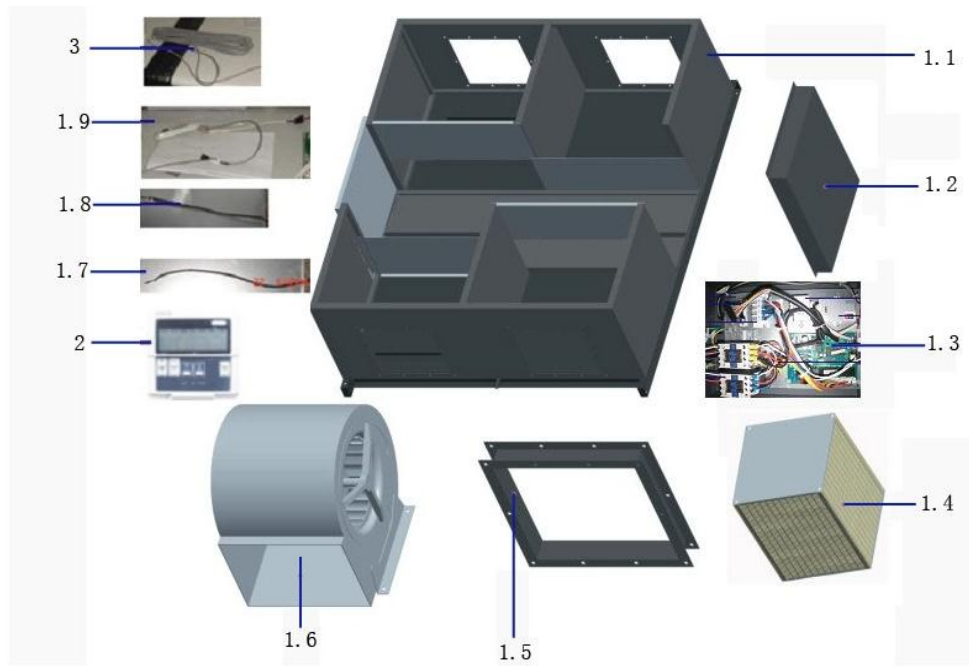

NO.	Part Name	Quantity
1.1	Chassis	1
1.2	Electrical box	1
1.3	Electrical box ass'y (RoHS)	1
1.4	Heat exchange core	2
1.5	Inlet/Outlet air	4
1.6	Fan	2
1.7	Room temp sensor ass'y (RoHS)	1
1.8	Temp. sensor (T1) (RoHS)	1
1.9	Display board ass'y (M54) (RoHS)	1
2	Wired Controller	1
3	Connecting wire assembly	1