

OMEGA Floor Ceiling Inverter Split

SUBMITTAL DATA

220-240V/1/50Hz

Job: _____
 Location: _____
 Schedule No.: _____
 System Designation: _____

Engineer: _____
 Architect: _____
 Date: _____
 For: Reference Approval Review Construction

FEATURES

Outdoor

- DC Inverter Rotary Compressor
- Phase Loss & Overcurrent Protection
- Corrosion-Resistant Cabinet
- Super Quiet Operation
- High-Efficiency Coils
- Low-Voltage Startup

Indoor

- Turbo Cooling Function
- Low Temperature Cooling
- Programmable 24 hours On/Off Timer
- Up to 16 SEER in Cooling Mode
- Super Quiet
- Anti-Mildew Dry Technology



1. Specifications

ICHD Mini Split Outdoor Unit



OUTDOOR UNIT

MODEL NO.	ICHD	009J 0A-DMG026	012J 0A-DMG035	018J 0A-DMG053	024J 0A-DMG071	031J 0A-DMG090	036J 0A-DMG105	042J 0A-DMG120	048J 0A-DMG140	060J 0A-DMG160
Compressor Type		DC Inverter Rotary								
Outdoor Fan	No of Fans	1	1	1	1	1	1	1	1	1
	Noise Level (dbA)	50	50	54	55	55	59	59	59	60
Coil Type:		Grooved Copper Tubes - Aluminum Blue Slit Fin								
Compressor	Rated Amps (RLA)	5.60	5.80	7.85	8.85	11.8	14.5	23.0	27.5	27.1
	Power Input Nom. (W)	649	1159	1602	2115	3060	3109	4559	5809	6600
Electrical	Voltage-Phase-Frequency	220-240V / 1Ph / N/A 3D								
	Range (min-max)	198 ~ 264								
	Min. Circuit Amps (MCA)	8.80	8.80	12.9	17.5	23.0	27.0	27.0	32.0	33.0
	Max Fuse Amps (MOCP)	15	15	20	25	30	30	30	40	40
Refrigerant R410 (oz./kgs.)		28.2 / 0.80	28.2 / 0.80	51.2 / 1.45	56.5 / 1.60	70.6 / 2.00	105.9 / 3.00	105.9 / 3.00	112.9 / 3.20	134.1 / 3.80
Refrigerant Connections inches (mm)	Type	Flare								
	Liquid	1/4 (6.35)	1/4 (6.35)	1/4 (6.35)	1/4 (6.35)	3/8 (9.52)	3/8 (9.52)	3/8 (9.52)	3/8 (9.52)	3/8 (9.52)
MAX Pipe Distance Ft.(m)	Suction	3/8 (9.52)	3/8 (9.52)	1/2 (12.7)	5/8 (15.9)	5/8 (15.9)	5/8 (15.9)	5/8 (15.9)	5/8 (15.9)	5/8 (15.9)
	Height	32.8 (10)	32.8 (10)	49.2 (15)	49.2 (15)	65.6 (20)	65.6 (20)	65.6 (20)	82.0 (25)	82.0 (25)
Dimensions inches (mm)	Length	49.2 (15)	49.2 (15)	82.0 (25)	82.0 (25)	98.4 (30)	98.4 (30)	98.4 (30)	164.0 (50)	164.0 (50)
	Height	21 1/8 (555)	21 1/8 (555)	21 1/8 (555)	28 (712)	28 (712)	33 1/8 (840)	33 1/8 (840)	33 1/8 (840)	34 1/8 (865)
	Width	28 3/8 (722)	28 3/8 (722)	31 1/4 (795)	35 7/8 (910)	35 7/8 (910)	37 3/8 (950)	37 3/8 (950)	37 3/8 (950)	41 (1040)
Net Weight	Depth	10 1/4 (260)	10 1/4 (260)	11 1/4 (287)	13 5/8 (345)	13 5/8 (345)	14 1/8 (360)	14 1/8 (360)	14 1/8 (360)	16 1/8 (410)
	Lbs (kgs)	55.1 (25.0)	56.2 (25.5)	73.9 (33.5)	103.6 (47.0)	112.4 (51.0)	149.9 (68.0)	149.9 (68.0)	173.1 (78.5)	200.6 (91.0)



OMEGA Floor Ceiling Inverter Split



1. Specifications

IEFC - Floor Ceiling Indoor Unit



INDOOR UNIT							
MODEL NO.	IEFC		018J 3A-DWG053	024J 3A-DWG071	036J 3A-DWG105	048J 3A-DWG140	060J 3A-DWG160
Cooling Capacity BTU/h (kW)	Nominal		18,000 (5.3)	24,000 (7.1)	36,000 (10.5)	48,000 (14.0)	60,000 (16.0)
	Minimum		3,410 (1.0)	8,190 (2.4)	10,235 (3.0)	14,330 (4.2)	14,330 (4.2)
	Maximum		20,470 (6.0)	27,980 (8.2)	39,240 (11.5)	48,450 (14.2)	54,590 (16.0)
Efficiency	SEER	BTU/h / W (W/W)	16.0 (4.69)				
Refrigerant Control		Electronic Expansion Valve @ Outdoor Unit Centrifugal					
Speed	Type						
	QTY Fan		1	1	2	2	2
			3	3	3	3	3
	Air Flow CFM (m³/hr) - Hi Noise		470 (800)	590 (1000)	1060 (1800)	1060 (1800)	1175 (2000)
	Level (dbA) Lo/Hi		40 / 47	41 / 48	44 / 50	44 / 50	45 / 52
Coil Type:		Grooved Copper Tubes - Aluminum Blue Slit Fin Cleanable					
Air Filter		Cartridge Type					
Electrical	Voltage-Phase-Frequency Range (min-max)		220-240V / 1Ph / 50Hz				
			198 ~ 264				
	FLA		0.57	0.59	0.45 * 2	0.45 * 2	0.73 * 2
	Power Input (W)		147	185	241	241	334
Controls		Wired Remote Control See					
Refrigerant Connections inches (mm) Drain		Outdoor Unit Data 1 (25)					
Connections inches (mm)		9 5/8 (244)					
Body Dimensions inches (mm)	Height		8 (203)	8 (203)	65 3/4 (1670)	9 5/8 (244)	11 1/4 (285)
	Width		39 (990)	50 3/8 (1280)	26 (660)	65 7/8 (1670)	65 3/4 (1670)
	Depth		26 (660)	26 (660)	109.1 (49.5)	26 (660)	26 (660)
Body Net Weight Lbs (kgs)			60.6 (27.5)	75.2 (34.1)		109.1 (49.5)	123.5 (56.0)

2. Dimensional Drawings

Unit:mm

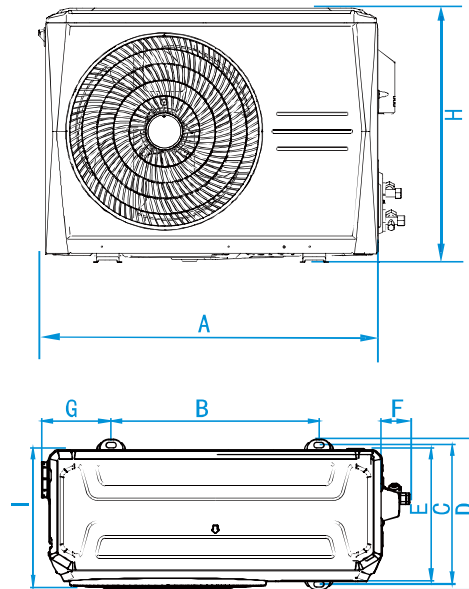
ICHD009J0A-DMG026 / ICHD012J0A-DMG035 / ICHD018J0A-DMG053 / ICHD024J0A-DMG071

Model	A	B	C	D	E	F	G	H	I
26	722	453	302	327	260	50	135	555	300
35/53	795	514	340	365	287	50	125	555	330
71	910	663	403	427	345	55	120	712	390

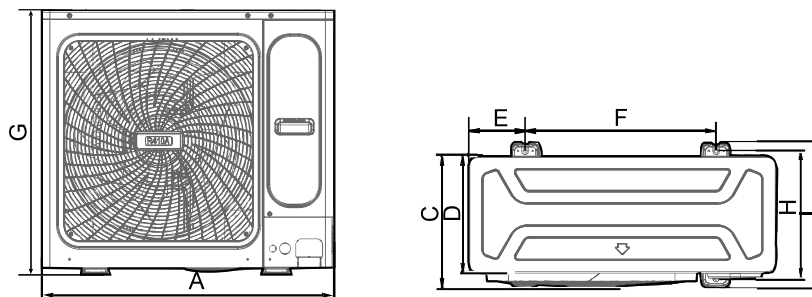
ICHD031J0A-DMG090 / ICHD036J0A-DMG105 / ICHD042J0A-DMG120 / ICHD048J0A-DMG140 / ICHD060J0A-DMG160

Model	A	C	D	E	F	G	H	I
90	910	390	345	120	663	712	403	427
105/120/140	950	406	360	175	590	840	390	440
160	1040	452	410	191	656	865	463	523

2. Dimensional Drawings

2.1 Indoor Unit

Unit:mm

Ceiling and Floor

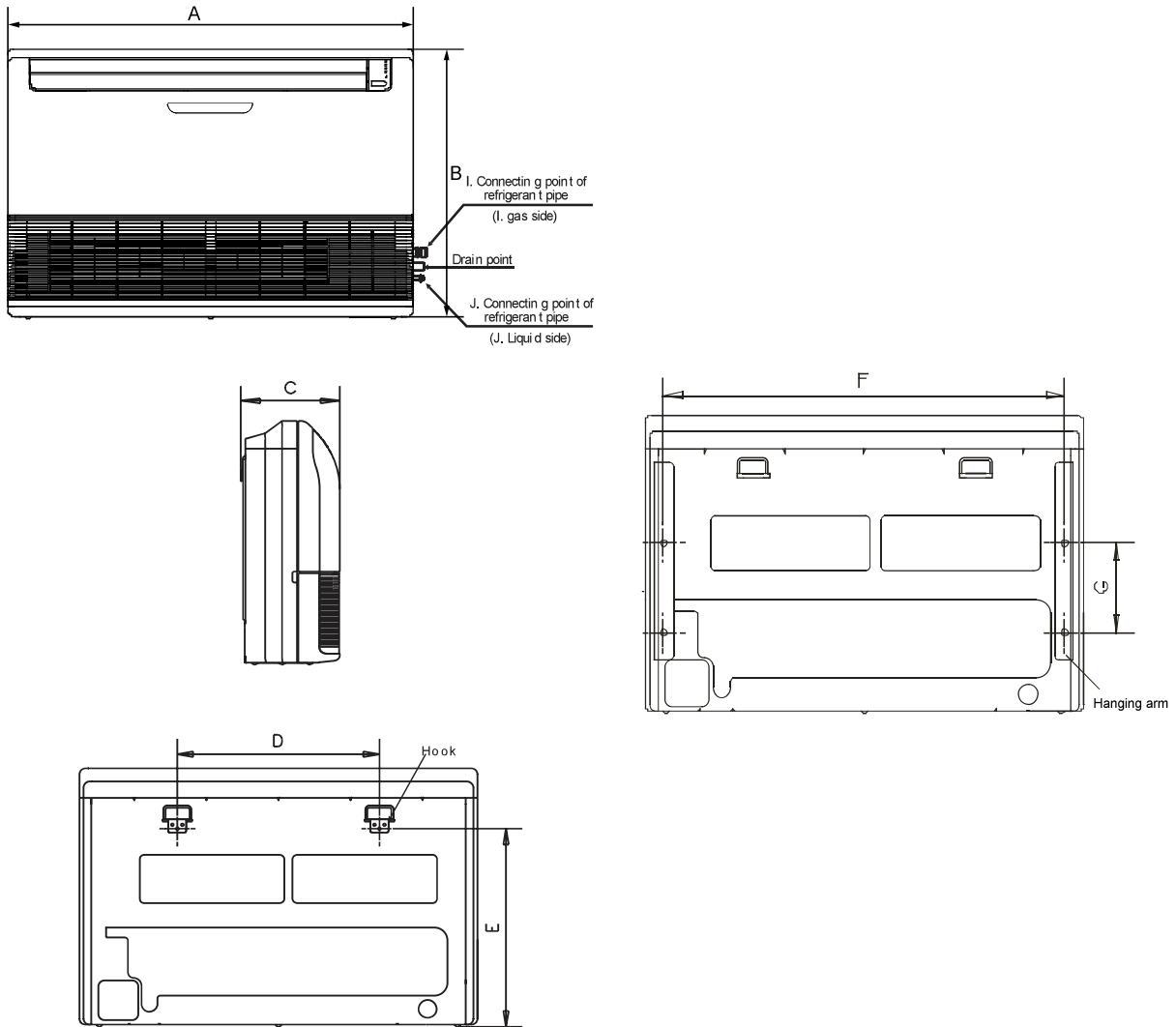

Model	A	B	C	D	E	F	G
IEFC018J3A-DWG053	990	660	203	505	506	907	200
IEFC024J3A-DWG071	1280	660	203	795	506	1195	200
IEFC036(48)J3A-DWG105(140)	1670	680	244	1070	450	1542	200
IEFC060J3A-DWG160	1670	680	285	1070	380	1613	200

2. Electric Characteristics

Model name	Power supply						Indoor fan motors	
	Hz	Volts	Min. volts	Max. volts	MCA	MFA	Rated motor output (kW)	FLA
IEFC018J3A	50	220-240	198	264	0.7125	25	0.055	0.57
IEFC024J3A	50	220-240	198	264	0.7375	32	0.061	0.59
IEFC036J3A	50	220-240	198	264	0.5625*2	15	0.059*2	0.45*2
IEFC048J3A	50	220-240	198	264	0.5625*2	15	0.059*2	0.45*2
IEFC060J3A	50	220-240	198	264	0.9125*2	15	0.09*2	0.73*2

Abbreviations:

MCA: Minimum Circuit Amps MFA: Maximum Fuse Amps FLA: Full Load Amps

3. Electric Characteristics

Model		Power Supply ¹							Compressor		OFM	
Capacity		Hz	Volts	Min.volts	Max.volts	MCA ²	TOCA ³	MFA ⁴	MSC ⁵	RLA ⁶	kW	FLA
ICHD009-DMG026		50	220-240	198	264	8.8	10	16	/	5.6	0.02	0.6
ICHD012-DMG035		50	220-240	198	264	8.8	10	16	/	5.8	0.02	0.6
ICHD018-DMG053		50	220-240	198	264	12.9	14.5	20	/	7.85	0.05	0.71
ICHD024-DMG071		50	220-240	198	264	17.5	20	25	/	8.85	0.08	1.0
ICHD031-DMG090		50	220-240	198	264	23	25	32	/	11.8	0.08	1.0
ICHD036-DMG105		50	220-240	198	264	27	28.5	32	/	14.5	0.17	1.53
ICHD042-DMG120		50	220-240	198	264	27	28.5	32	/	23	0.17	1.53
ICHD048-DMG140		50	220-240	198	264	32	35.2	40	/	27.5	0.17	1.53
ICHD060-DMG160		50	220-240	198	264	33	35	40	/	27.1	0.17	1.53

Abbreviations:

MCA: Minimum Circuit Amps; TOCA: Total Over-current Amps; MFA: Maximum Fuse Amps; MSC: Maximum Starting Current (A); RLA: Rated Load Amps; FLA: Full Load Amps

Notes:

- Units are suitable for use on electrical systems where voltage supplied to unit terminals is not below or above listed range limits. Maximum allowable voltage variation between phases is 2%.
- Select wire size based on the value of MCA.
TOCA indicates the total overcurrent amps value of each OC set.
MFA is used to select overcurrent circuit breakers and residual-current circuit breakers.
MSC indicates the maximum current on compressor start-up in amps.
RLA is based on the following conditions: indoor temperature 27°C DB, 19°C WB; outdoor temperature 35°C DB.