

OMEGA MINI VRF ULTIMA

SUBMITTAL DATA

208~230V/1/50-60Hz

Job: _____
 Location: _____
 Schedule No.: _____
 System Designation: _____

Engineer: _____
 Architect: _____
 Date: _____
 For: Reference Approval Review Construction

FEATURES

- Anti-Corrosion Protection
- Refrigerant-Cooled PCB Board
- Welding Free Branch Piping
- Linear Capacity Match with IDU
- Automatic Fault Detection
- Intelligent Soft Start
- Cooling and Heating System
- Full DC Inverter Technology

Models: 15~50 Kbtu/h



Models: 60~80 Kbtu/h

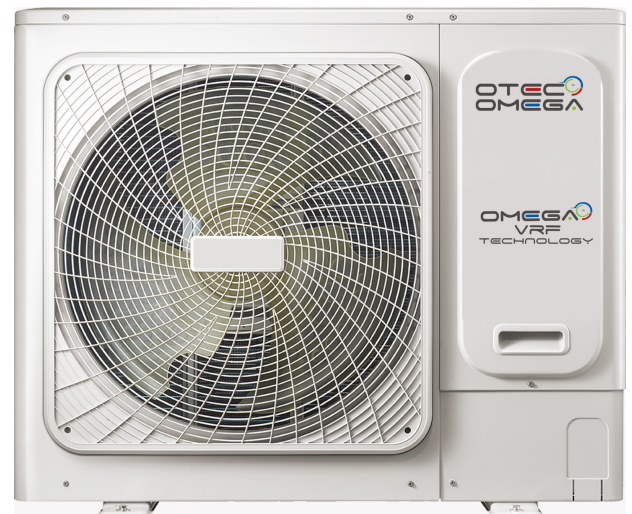

1. Specifications

BCHB Mini VRF Ultima

Model		BCHB015Q0A3-DTM040	BCHB020Q0A3-DTM060	BCHB025Q0A3-DTM070	
Power supply		V-Ph-Hz	208-230/1/ 50(60)		
Cooling ¹	Capacity	kBtu/h	12	18	21
		kW	3.5	5.3	6.2
	Input	kW	0.94	1.47	1.85
	EER	kW/ kW	3.71	3.6	3.35
Heating ²	Capacity	kBtu/h	13	20	20.5
		kW	3.8	5.8	6.0
	Input	kW	0.88	1.35	1.41
	COP	kW/ kW	4.43	4.3	4.25
Connectable indoor unit	Total capacity		45~130% of outdoor unit capacity		
	Quantity		1~3	1~3	1~3
Compressor	Type		DC inverter	DC inverter	DC inverter
	Quantity		1	1	1
	Oil type		RB74AF	RB74AF	RB74AF
Fan	Motor type		DC motor	DC motor	DC motor
	Quantity		1	1	1
	Output	W	65	65	65
Outdoor air flow		m3/h	2500	2700	2700
Sound pressure level ³		dB(A)	53	54	55
Net dimensions (W×H×D) ⁴		mm	795 x 555 x 365	795 x 555 x 365	795 x 555 x 365
Packed dimensions (W×H×D)		mm	915 x 610 x 420	915 x 610 x 420	915 x 610 x 420
Net weight		kg	35	35	35
Gross weight		kg	38.5	38.5	38.5
Refrigerant	Type		R410A	R410A	R410A
	Factory charge	g	1450	1450	1450
	Throttle type		Electronic expansion valve		
Pipe connections	Liquid pipe	mm	Φ6.35	Φ6.35	Φ9.53
	Gas pipe	mm	Φ12.7	Φ12.7	Φ15.9
Ambient Temp. operation range	Cooling	°C	-15~55 ⁶		
	Heating	°C	-15~27		

Notes:

- The cooling conditions: indoor temp: 27 °C DB (80.6 °F), 19 °C WB (66.2 °F) outdoor temp: 35 °C DB (95 °F) equivalent pipe length: 5m drop length: 0m.
- The heating conditions: indoor temp: 20 °C DB (68 °F), 15 °C WB (44.6 °F) outdoor temp.: 7 °C DB (42.8 °F) equivalent pipe length: 5m drop length: 0m.
- Sound level: Anechoic chamber conversion value, measured at a point 1 m in front of the unit at a height of 1m for 28/26 model, 1.2m for 42 model. During actual operation, these values are normally somewhat higher as a result of ambient conditions.
- Diameters given are those of the unit's stop valves.
- The above data may be changed without notice for future improvement on quality and performance.
- When the cooling ambient temperature is below -5°C, the capacity of the IDU must be limited to at least 30% of the capacity of the the combined capacity of ODU.

Conversion Formulae:
 kBtu/h = kW × 3.412;
 in.W.G. = Pa × 0.004;
 lbs. = kg × 2.2;
 in. = mm / 25.4

1. Specifications

BCHB Mini VRF Ultima

Model			BCHB030Q0A4-DTM090	BCHB040Q0A6-DTM115	BCHB050Q0A7-DTM140
Power supply		V-Ph-Hz	208-230/1/ 50(60)		
Cooling ¹	Capacity	kBtu/h	27	34	42
		kW	8	10	12.3
	Input	kW	2.1	2.66	3.39
	EER	kW/ KW	3.81	3.76	3.63
Heating ²	Capacity	kBtu/h	30	41	47
		kW	9	12	14
	Input	kW	2.04	3.15	3.64
	COP	kW/ kW	4.41	3.81	3.85
Connectable indoor unit	Total capacity		45~130% of outdoor unit capacity		
	Quantity		1~4	1~6	1~7
Compressor	Type		DC inverter	DC inverter	DC inverter
	Quantity		1	1	1
	Oil type		RB74AF	VG74	VG74
Fan	Motor type		DC motor	DC motor	DC motor
	Quantity		1	1	1
	Output	W	80	80	170
Outdoor air flow		m3/h	3750	4000	5000
Sound pressure level ³		dB(A)	54	54	56
Net dimensions (W×H×D) ⁴		mm	910 x 712 x 426	910 x 712 x 426	950 x 840 x 440
Packed dimensions (W×H×D)		mm	1045 x 810 x 485	1045 x 810 x 485	1025 x 950 x 510
Net weight		kg	49	52.5	62.5
Gross weight		kg	53	56.5	69.5
Refrigerant	Type		R410A	R410A	R410A
	Factory charge	g	1700	2600	3200
	Throttle type		Electronic expansion valve		
Pipe connections	Liquid pipe	mm	Φ9.53	Φ9.53	Φ9.53
	Gas pipe	mm	Φ15.9	Φ15.9	Φ15.9
Ambient Temp. operation range	Cooling	°C	-15~55 ⁶		
	Heating	°C	-15~27		

Notes:

- The cooling conditions: indoor temp: 27 °C DB (80.6 °F), 19 °C WB (66.2 °F) outdoor temp: 35 °C DB (95 °F) equivalent pipe length: 5m drop length: 0m.
- The heating conditions: indoor temp: 20 °C DB (68 °F), 15 °C WB (44.6 °F) outdoor temp.: 7 °C DB (42.8 °F) equivalent pipe length: 5m drop length: 0m.
- Sound level: Anechoic chamber conversion value, measured at a point 1 m in front of the unit at a height of 1m for 28/26 model, 1.2m for 42 model. During actual operation, these values are normally somewhat higher as a result of ambient conditions.
- Diameters given are those of the unit's stop valves.
- The above data may be changed without notice for future improvement on quality and performance.
- When the cooling ambient temperature is below -5°C, the capacity of the IDU must be limited to at least 30% of the capacity of the the combined capacity of ODU.

Conversion Formulae:
 kBtu/h = kW × 3.412;
 in.W.G. = Pa × 0.004;
 lbs. = kg × 2.2;
 in. = mm / 25.4

1. Specifications

BCHB Mini VRF Ultima

Model			BCHB060Q0A8-DTM160	BCHB070Q0A9-DTM190	BCHB080Q0A9-DTM200
Power supply		V-Ph-Hz	208-230/1/ 50(60)		
Cooling ¹	Capacity	kBtu/h	47	52	59
		kW	14	15.5	17.5
	Input	kW	3.97	4.87	6.12
	EER	kW/ KW	3.53	3.18	2.86
Heating ²	Capacity	kBtu/h	54	61	66
		kW	16	18	19.5
	Input	kW	3.98	4.82	5.57
	COP	kW/ kW	4.02	3.73	3.50
Connectable indoor unit	Total capacity		45~130% of outdoor unit capacity		
	Quantity		1~8	1~9	1~9
Compressor	Type		DC inverter	DC inverter	DC inverter
	Quantity		1	1	1
	Oil type		RB74AF	RB74AF	RB74AF
Fan	Motor type		DC motor	DC motor	DC motor
	Quantity		1	1	1
	Output	W	170	170	170
Outdoor air flow		m3/h	5200	5000	5300
Sound pressure level ³		dB(A)	56	56	57
Net dimensions (W×H×D) ⁴		mm	950 x 840 x 440	950 x 840 x 440	1040 x 865 x 523
Packed dimensions (W×H×D)		mm	1025 x950 x 510	1025 x950 x 510	1120 x 980 x 560
Net weight		kg	75	77.5	91
Gross weight		kg	82	84.5	99
Refrigerant	Type		R410A	R410A	R410A
	Factory charge	g	3100	3600	4600
	Throttle type		Electronic expansion valve		
Pipe connections	Liquid pipe	mm	Φ9.53	Φ9.53	Φ9.53
	Gas pipe	mm	Φ15.9	Φ19.1	Φ19.1
Ambient Temp. operation range	Cooling	°C	-15~55 ⁶		
	Heating	°C	-15~27		

Notes:

- The cooling conditions: indoor temp: 27 °C DB (80.6 °F), 19 °C WB (66.2 °F) outdoor temp: 35 °C DB (95 °F) equivalent pipe length: 5m drop length: 0m.
- The heating conditions: indoor temp: 20 °C DB (68 °F), 15 °C WB (44.6 °F) outdoor temp.: 7 °C DB (42.8 °F) equivalent pipe length: 5m drop length: 0m.
- Sound level: Anechoic chamber conversion value, measured at a point 1 m in front of the unit at a height of 1m for 28/26 model, 1.2m for 42 model. During actual operation, these values are normally somewhat higher as a result of ambient conditions.
- Diameters given are those of the unit's stop valves.
- The above data may be changed without notice for future improvement on quality and performance.
- When the cooling ambient temperature is below -5°C, the capacity of the IDU must be limited to at least 30% of the capacity of the the combined capacity of ODU.

Conversion Formulae:
 kBtu/h = kW × 3.412;
 in.W.G. = Pa × 0.004;
 lbs. = kg × 2.2;
 in. = mm / 25.4

2 Dimensional Drawings - (MM)

Figure 2-2.1: Model 12-21 Front view dimensions

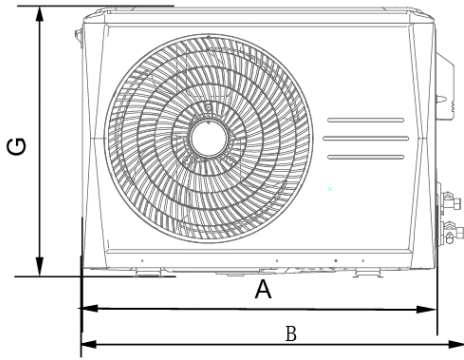

Figure 2-2.2: Model 12-21 Top view dimensions

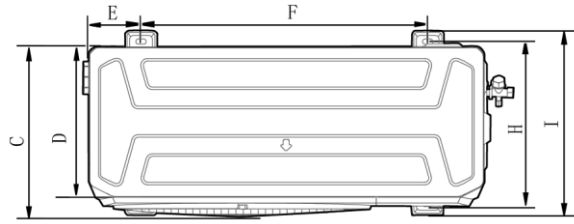

Figure 2-2.1: Model 28-36 Front view dimensions

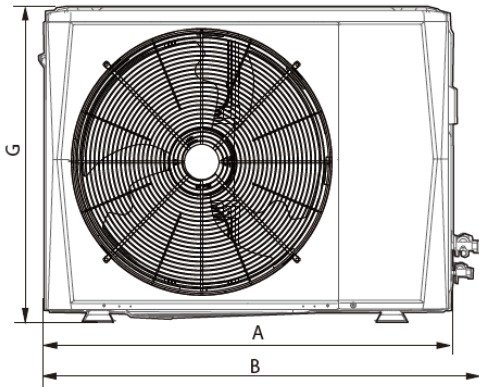

Figure 2-2.2: Model 28-36 Top view dimensions

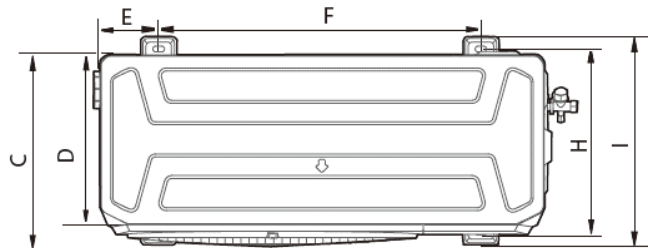

Figure 2-2.3: Model 42-56 Front view dimensions

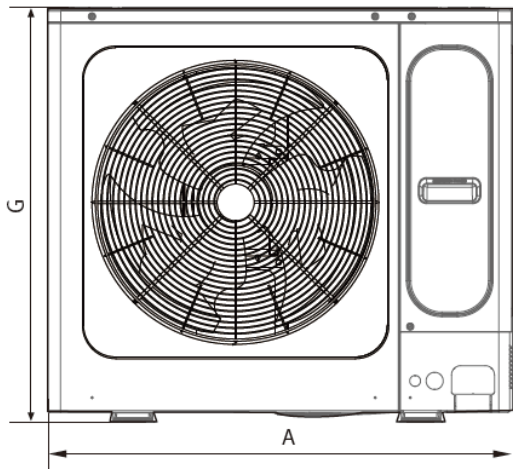

Figure 2-2.4: Model 42-56 Top view dimensions

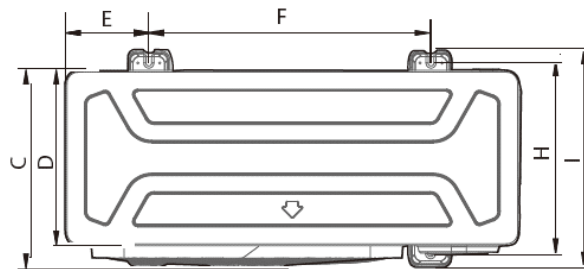

Figure 2-2.5: Model 60 Front view dimensions

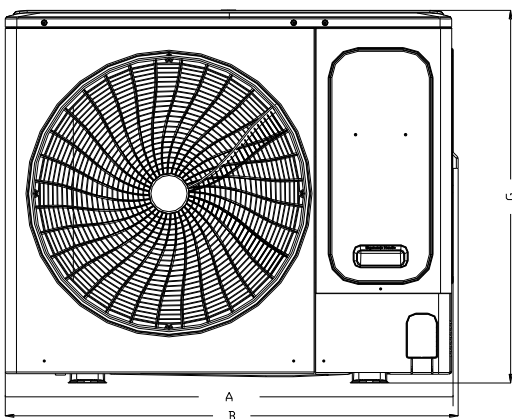
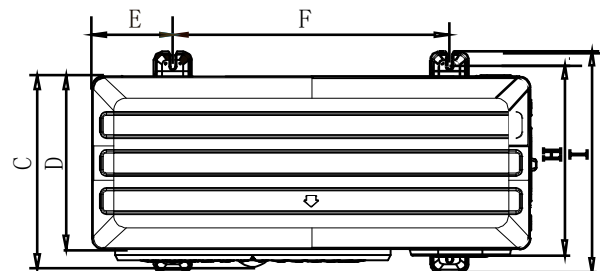
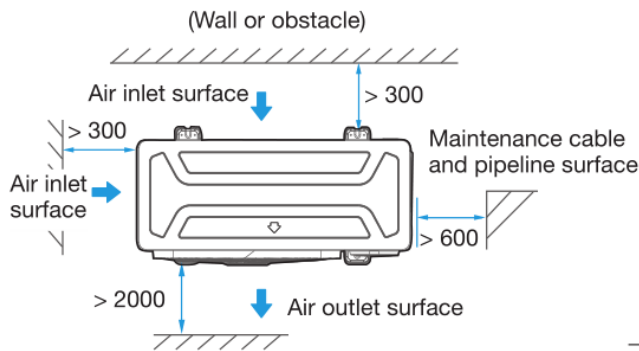
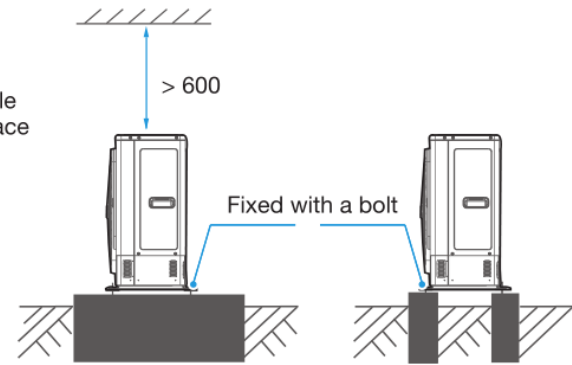
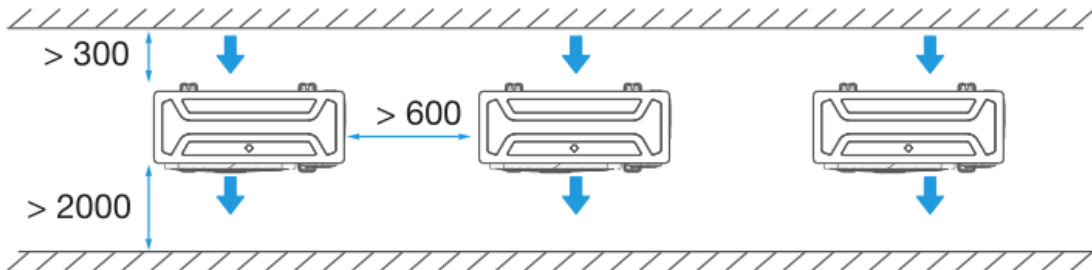
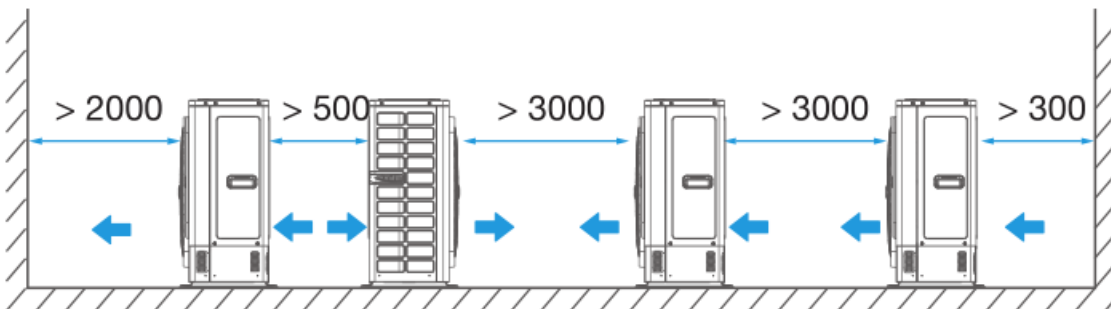

Figure 2-2.6: Model 60 Top view dimensions



2 Dimensional Drawings - (MM)

Model	A	B	C	D	E	F	G	H	I
12/18/21	795	845	330	287	125	514	555	340	365
28/36	910	982	390	345	120	663	712	375	426
42/48/56	950	/	406	360	175	590	840	390	440
60	1040	1053	452	410	191	656	865	463	523

Installation Space Requirements
Figure 2-3.1: Single unit installation top view (unit: mm)

Figure 2-3.2: Single unit installation side view (unit: mm)

Figure 2-3.3: Multiple unit installation top view (unit: mm)

Figure 2-3.4: Multiple unit installation side view (unit: mm)

3-Electrical Characteristics
6 Electrical Characteristics
Table 2-6.1: Outdoor unit electrical characteristics

Model	Power Supply ¹							Compressor		OFM	
	Hz	Volts	Min.	Max.	MCA ²	TOCA ³	MFA ⁴	MSC ⁵	RLA ⁶	kW	FLA
			volts	volts							
BCHB015Q0A3-DTM040	50/60Hz	220-240	198	264	10	10	16	Soft start	8	0.08	0.53
BCHB020Q0A3-DTM060	50/60Hz	220-240	198	264	16.3	15	20	Soft start	13	0.08	0.53
BCHB025Q0A3-DTM070	50/60Hz	220-240	198	264	16.3	15	20	Soft start	13	0.08	0.53
BCHB030Q0A4-DTM090	50/60Hz	220-240	198	264	21.25	18.1	25	Soft start	17	0.08	1.0
BCHB040Q0A6-DTM115	50/60Hz	220-240	198	264	28.75	24	32	Soft start	23	0.17	1.52
BCHB050Q0A7-DTM140	50/60Hz	220-240	198	264	35	29	40	Soft start	28	0.17	1.52
BCHB060Q0A8-DTM160	50/60Hz	220-240	198	264	40	33	40	Soft start	32	0.17	1.52
BCHB070Q0A9-DTM190	50/60Hz	220-240	198	264	40	33	40	Soft start	32	0.17	1.52
BCHB080Q0A9-DTM200	50/60Hz	220-240	198	264	40	33	40	Soft start	32	0.17	1.52

Abbreviations:

MCA: Minimum Circuit Amps; TOCA: Total Over-current Amps; MFA: Maximum Fuse Amps; MSC: Maximum Starting Current (A); RLA: Rated Load Amps; FLA: Full Load Amps

Notes:

- Units are suitable for use on electrical systems where voltage supplied to unit terminals is not below or above listed range limits. Maximum allowable voltage variation between phases is 2%.
- Select wire size based on the value of MCA.
- TOCA indicates the total overcurrent amps value of each OC set.
- MFA is used to select overcurrent circuit breakers and residual-current circuit breakers.
- MSC indicates the maximum current on compressor start-up in amps.
- RLA is based on the following conditions: indoor temperature 27°C DB, 19°C WB; outdoor temperature 35°C DB.



17702 Mitchell North, #101
Irvine, CA. 92614 .USA
Tel: 714 795 2830
Fax: 714 966 1646
info@omegainverter.com
www.omegainverter.com



Showroom & Technology Center
11380 Interchange Circle North
Miramar, FL 33025 .USA
Tel: 305 901 1270
Fax: 954-212-8280
info@otecomega.com
www.otecomega.com